



## Human error: models and management

James Reason

BMJ 2000;320:768-770

doi:10.1136/bmj.320.7237.768

---

Updated information and services can be found at:  
<http://bmj.com/cgi/content/full/320/7237/768>

---

*These include:*

### References

80 online articles that cite this article can be accessed at:  
<http://bmj.com/cgi/content/full/320/7237/768#otherarticles>

### Rapid responses

You can respond to this article at:  
<http://bmj.com/cgi/eletter-submit/320/7237/768>

### Email alerting service

Receive free email alerts when new articles cite this article - sign up in the box at the top right corner of the article

---

### Topic collections

Articles on similar topics can be found in the following collections

Other management (279 articles)  
Quality improvement (including CQI and TQM) (560 articles)  
Psychology (385 articles)

---

### Notes

---

To order reprints of this article go to:  
<http://www.bmjournals.com/cgi/reprintform>

To subscribe to *BMJ* go to:  
<http://bmj.bmjournals.com/subscriptions/subscribe.shtml>

# Education and debate

## Human error: models and management

James Reason

Department of  
Psychology,  
University of  
Manchester,  
Manchester,  
M13 9PL.  
James Reason  
*professor of psychology*  
reason@psy.  
man.ac.uk

BMJ 2000;320:768-70

The human error problem can be viewed in two ways: the person approach and the system approach. Each has its model of error causation and each model gives rise to quite different philosophies of error management. Understanding these differences has important practical implications for coping with the ever present risk of mishaps in clinical practice.

### Person approach

The longstanding and widespread tradition of the person approach focuses on the unsafe acts—errors and procedural violations—of people at the sharp end: nurses, physicians, surgeons, anaesthetists, pharmacists, and the like. It views these unsafe acts as arising primarily from aberrant mental processes such as forgetfulness, inattention, poor motivation, carelessness, negligence, and recklessness. Naturally enough, the associated countermeasures are directed mainly at reducing unwanted variability in human behaviour. These methods include poster campaigns that appeal to people's sense of fear, writing another procedure (or adding to existing ones), disciplinary measures, threat of litigation, retraining, naming, blaming, and shaming. Followers of this approach tend to treat errors as moral issues, assuming that bad things happen to bad people—what psychologists have called the just world hypothesis.<sup>1</sup>

### System approach

The basic premise in the system approach is that humans are fallible and errors are to be expected, even in the best organisations. Errors are seen as consequences rather than causes, having their origins not so much in the perversity of human nature as in "upstream" systemic factors. These include recurrent error traps in the workplace and the organisational processes that give rise to them. Countermeasures are based on the assumption that though we cannot change the human condition, we can change the conditions under which humans work. A central idea is that of system defences. All hazardous technologies possess barriers and safeguards. When an adverse event occurs, the important issue is not who blundered, but how and why the defences failed.

### Evaluating the person approach

The person approach remains the dominant tradition in medicine, as elsewhere. From some perspectives it

### Summary points

Two approaches to the problem of human fallibility exist: the person and the system approaches

The person approach focuses on the errors of individuals, blaming them for forgetfulness, inattention, or moral weakness

The system approach concentrates on the conditions under which individuals work and tries to build defences to avert errors or mitigate their effects

High reliability organisations—which have less than their fair share of accidents—recognise that human variability is a force to harness in averting errors, but they work hard to focus that variability and are constantly preoccupied with the possibility of failure

has much to commend it. Blaming individuals is emotionally more satisfying than targeting institutions. People are viewed as free agents capable of choosing between safe and unsafe modes of behaviour. If something goes wrong, it seems obvious that an individual (or group of individuals) must have been responsible. Seeking as far as possible to uncouple a person's unsafe acts from any institutional responsibility is clearly in the interests of managers. It is also legally more convenient, at least in Britain.

Nevertheless, the person approach has serious shortcomings and is ill suited to the medical domain. Indeed, continued adherence to this approach is likely to thwart the development of safer healthcare institutions.

Although some unsafe acts in any sphere are egregious, the vast majority are not. In aviation maintenance—a hands-on activity similar to medical practice in many respects—some 90% of quality lapses were judged as blameless.<sup>2</sup> Effective risk management depends crucially on establishing a reporting culture.<sup>3</sup> Without a detailed analysis of mishaps, incidents, near misses, and "free lessons," we have no way of uncovering recurrent error traps or of knowing where the "edge" is until we fall over it. The complete absence of such a reporting culture within the Soviet Union contributed crucially to the Chernobyl disaster.<sup>4</sup> Trust is a

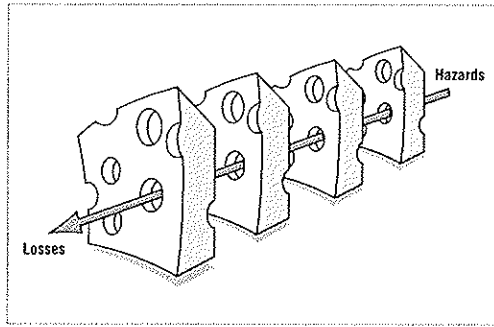

The Swiss cheese model of how defences, barriers, and safeguards may be penetrated by an accident trajectory

key element of a reporting culture and this, in turn, requires the existence of a just culture—one possessing a collective understanding of where the line should be drawn between blameless and blameworthy actions.<sup>3</sup> Engineering a just culture is an essential early step in creating a safe culture.

Another serious weakness of the person approach is that by focusing on the individual origins of error it isolates unsafe acts from their system context. As a result, two important features of human error tend to be overlooked. Firstly, it is often the best people who make the worst mistakes—error is not the monopoly of an unfortunate few. Secondly, far from being random, mishaps tend to fall into recurrent patterns. The same set of circumstances can provoke similar errors, regardless of the people involved. The pursuit of greater safety is seriously impeded by an approach that does not seek out and remove the error provoking properties within the system at large.

### The Swiss cheese model of system accidents

Defences, barriers, and safeguards occupy a key position in the system approach. High technology systems have many defensive layers: some are engineered (alarms, physical barriers, automatic shutdowns, etc), others rely on people (surgeons, anaesthetists, pilots, control room operators, etc), and yet others depend on procedures and administrative controls. Their function is to protect potential victims and assets from local hazards. Mostly they do this very effectively, but there are always weaknesses.

In an ideal world each defensive layer would be intact. In reality, however, they are more like slices of Swiss cheese, having many holes—though unlike in the cheese, these holes are continually opening, shutting, and shifting their location. The presence of holes in any one “slice” does not normally cause a bad outcome. Usually, this can happen only when the holes in many layers momentarily line up to permit a trajectory of accident opportunity—bringing hazards into damaging contact with victims (figure).

The holes in the defences arise for two reasons: active failures and latent conditions. Nearly all adverse events involve a combination of these two sets of factors.

*Active failures* are the unsafe acts committed by people who are in direct contact with the patient or system. They take a variety of forms: slips, lapses, fumbles, mistakes, and procedural violations.<sup>4</sup> Active

failures have a direct and usually shortlived impact on the integrity of the defences. At Chernobyl, for example, the operators wrongly violated plant procedures and switched off successive safety systems, thus creating the immediate trigger for the catastrophic explosion in the core. Followers of the person approach often look no further for the causes of an adverse event once they have identified these proximal unsafe acts. But, as discussed below, virtually all such acts have a causal history that extends back in time and up through the levels of the system.

*Latent conditions* are the inevitable “resident pathogens” within the system. They arise from decisions made by designers, builders, procedure writers, and top level management. Such decisions may be mistaken, but they need not be. All such strategic decisions have the potential for introducing pathogens into the system. Latent conditions have two kinds of adverse effect: they can translate into error provoking conditions within the local workplace (for example, time pressure, understaffing, inadequate equipment, fatigue, and inexperience) and they can create longlasting holes or weaknesses in the defences (untrustworthy alarms and indicators, unworkable procedures, design and construction deficiencies, etc). Latent conditions—as the term suggests—may lie dormant within the system for many years before they combine with active failures and local triggers to create an accident opportunity. Unlike active failures, whose specific forms are often hard to foresee, latent conditions can be identified and remedied before an adverse event occurs. Understanding this leads to proactive rather than reactive risk management.

■ *We cannot change the human condition, but we can change the conditions under which humans work*

To use another analogy: active failures are like mosquitoes. They can be swatted one by one, but they still keep coming. The best remedies are to create more effective defences and to drain the swamps in which they breed. The swamps, in this case, are the ever present latent conditions.

### Error management

Over the past decade researchers into human factors have been increasingly concerned with developing the tools for managing unsafe acts. Error management has two components: limiting the incidence of dangerous errors and—since this will never be wholly effective—creating systems that are better able to tolerate the occurrence of errors and contain their damaging effects. Whereas followers of the person approach direct most of their management resources at trying to make individuals less fallible or wayward, adherents of the system approach strive for a comprehensive management programme aimed at several different targets: the person, the team, the task, the workplace, and the institution as a whole.<sup>5</sup>

High reliability organisations—systems operating in hazardous conditions that have fewer than their fair share of adverse events—offer important models for what constitutes a resilient system. Such a system has

### High reliability organisations

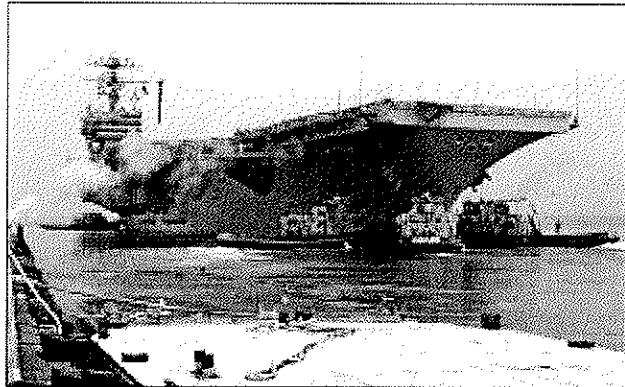

So far, three types of high reliability organisations have been investigated: US Navy nuclear aircraft carriers, nuclear power plants, and air traffic control centres. The challenges facing these organisations are twofold:

- Managing complex, demanding technologies so as to avoid major failures that could cripple or even destroy the organisation concerned
- Maintaining the capacity for meeting periods of very high peak demand, whenever these occur.

The organisations studied<sup>7, 8</sup> had these defining characteristics:

- They were complex, internally dynamic, and, intermittently, intensely interactive
- They performed exacting tasks under considerable time pressure
- They had carried out these demanding activities with low incident rates and an almost complete absence of catastrophic failures over several years.

Although, on the face of it, these organisations are far removed from the medical domain, they share important characteristics with healthcare institutions. The lessons to be learnt from these organisations are clearly relevant for those who manage and operate healthcare institutions.

intrinsic "safety health"; it is able to withstand its operational dangers and yet still achieve its objectives.

### Some paradoxes of high reliability

Just as medicine understands more about disease than health, so the safety sciences know more about what causes adverse events than about how they can best be avoided. Over the past 15 years or so, a group of social scientists based mainly at Berkeley and the University of Michigan has sought to redress this imbalance by studying safety successes in organisations rather than their infrequent but more conspicuous failures.<sup>7, 8</sup> These success stories involved nuclear aircraft carriers, air traffic control systems, and nuclear power plants (box). Although such high reliability organisations may seem remote from clinical practice, some of their defining cultural characteristics could be imported into the medical domain.

Most managers of traditional systems attribute human unreliability to unwanted variability and strive to eliminate it as far as possible. In high reliability organisations, on the other hand, it is recognised that human variability in the shape of compensations and adaptations to changing events represents one of the system's most important safeguards. Reliability is "a dynamic non-event." It is dynamic because safety is preserved by timely human adjustments; it is a non-event because successful outcomes rarely call attention to themselves.

High reliability organisations can reconfigure themselves to suit local circumstances. In their routine mode, they are controlled in the conventional hierarchical manner. But in high tempo or emergency situations, control shifts to the experts on the spot—as it often does in the medical domain. The organisation reverts seamlessly to the routine control mode once the crisis has passed. Paradoxically, this flexibility arises in part from a military tradition—even civilian high reliability organisations have a large proportion of ex-military staff. Military organisations tend to define their goals in an unambiguous way and, for these bursts of semiautonomous activity to be successful, it is essential that all the participants clearly understand and share these aspirations. Although high reliability organisations expect and encourage variability of human action, they also work very hard to maintain a consistent mindset of intelligent wariness.<sup>8</sup>

### Blaming individuals is emotionally more satisfying than targeting institutions.

Perhaps the most important distinguishing feature of high reliability organisations is their collective preoccupation with the possibility of failure. They expect to make errors and train their workforce to recognise and recover them. They continually rehearse familiar scenarios of failure and strive hard to imagine novel ones. Instead of isolating failures, they generalise them. Instead of making local repairs, they look for system reforms.

### Conclusions

High reliability organisations are the prime examples of the system approach. They anticipate the worst and equip themselves to deal with it at all levels of the organisation. It is hard, even unnatural, for individuals to remain chronically uneasy, so their organisational culture takes on a profound significance. Individuals may forget to be afraid, but the culture of a high reliability organisation provides them with both the reminders and the tools to help them remember. For these organisations, the pursuit of safety is not so much about preventing isolated failures, either human or technical, as about making the system as robust as is practicable in the face of its human and operational hazards. High reliability organisations are not immune to adverse events, but they have learnt the knack of converting these occasional setbacks into enhanced resilience of the system.

Competing interests: None declared.

- 1 Lerner MJ. The desire for justice and reactions to victims. In: McCauley J, Berkowitz J, eds. *Altruism and helping behavior*. New York: Academic Press, 1970.
- 2 Marx D. Discipline: the role of rule violations. *Criminal Effects* 1997;2:1-1.
- 3 Reason J. *Managing the risks of organisational accidents*. Aldershot: Ashgate, 1997.
- 4 Medvedev G. *The truth about Chernobyl*. New York: Basic Books, 1991.
- 5 Marx D. *Maintenance error causation*. Washington, DC: Federal Aviation Authority Office of Aviation Medicine, 1999.
- 6 Reason J. *Human error*. New York: Cambridge University Press, 1990.
- 7 Weick KE. Organizational culture as a source of high reliability. *Calif Management Rev* 1987;29:112-27.
- 8 Weick KE, Sutcliffe KM, Obstfeld D. Organizing for high reliability: processes of collective mindfulness. *Res Organizational Behav* 1999;21: 22-51.